

Quad SPST CMOS Analog Switches

Features

- Low On-Resistance: 50 Ω
- Low Leakage: 80 pA
- Low Power Consumption: 22 nW
- Fast Switching Action— t_{ON} : 120 ns
- Low Charge Injection
- DG211/DG212 Upgrades
- TTL/CMOS Logic Compatible

Benefits

- Low Signal Errors and Distortion
- Reduced Power Supply Requirements
- Faster Throughput
- Improved Reliability
- Reduced Pedestal Errors
- Simple Interfacing

Applications

- Audio Switching
- Battery Powered Systems
- Data Acquisition
- Sample-and-Hold Circuits
- Telecommunication Systems
- Automatic Test Equipment
- Single Supply Circuits
- Hard Disk Drives

Description

The DG444/DG445 monolithic quad analog switches are designed to provide high speed, low error switching of analog signals. The DG444 has a normally closed function. The DG445 has a normally open function. Combining low power (22 nW, typ) with high speed (t_{ON} : 120 ns, typ), the DG444/DG445 are ideally suited for upgrading DG211/212 sockets. Charge injection has been minimized on the drain for use in sample-and-hold circuits.

To achieve high-voltage ratings and superior switching performance, the DG444/DG445 are built on Siliconix's high-voltage silicon-gate process. An epitaxial layer prevents latchup.

Each switch conducts equally well in both directions when on, and blocks input voltages to the supply levels when off.

Functional Block Diagram and Pin Configuration

DG444

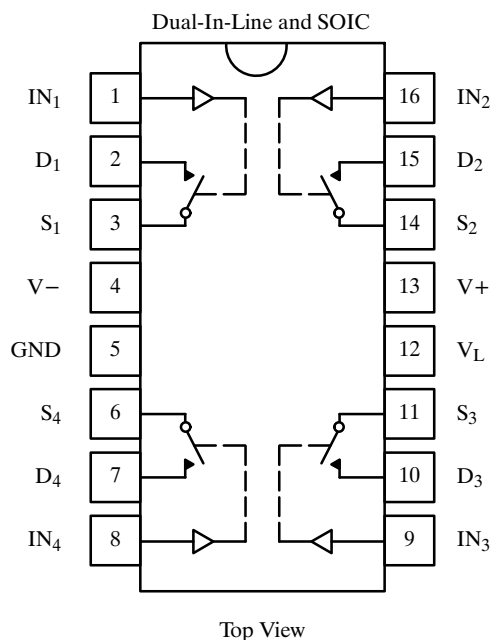

Truth Table

Logic	DG444	DG445
0	ON	OFF
1	OFF	ON

Logic "0" \leq 0.8 V, Logic "1" \geq 2.4 V

Switches Shown for DG444 Logic "1" Input

Ordering Information

Temp Range	Package	Part Number
-40°C to 85°C	16-Pin Plastic DIP	DG444DJ
		DG445DJ
	16-Pin Narrow SOIC	DG444DY
		DG445DY

Absolute Maximum Ratings

V+ to V-	44 V
GND to V-	25 V
V _L	(GND - 0.3 V) to (V+) + 0.3 V
Digital Inputs ^a V _S , V _D	(V-) - 2 V to (V+) + 2 V or 30 mA, whichever occurs first
Continuous Current (Any Terminal)	30 mA
Current, S or D (Pulsed 1 ms, 10% duty cycle)	100 mA
Storage Temperature	-65 to 125°C

Power Dissipation (Package) ^b	
16-Pin Plastic DIP ^c	450 mW
16-Pin Narrow Body SOIC ^d	600 mW

Notes:

- Signals on S_X, D_X, or I_{NX} exceeding V+ or V- will be clamped by internal diodes. Limit forward diode current to maximum current ratings.
- All leads welded or soldered to PC Board.
- Derate 6 mW/°C above 75°C
- Derate 12 mW/°C above 75°C

Specifications for Dual Supplies

Parameter	Symbol	Test Conditions Unless Otherwise Specified V+ = 15 V, V- = -15 V V _L = 5 V, V _{IN} = 2.4 V, 0.8 V ^e	Temp ^a	D Suffix -40 to 85°C			Unit		
				Min ^c	Typ ^b	Max ^c			
Analog Switch									
Analog Signal Range ^d	V _{ANALOG}		Full	-15		15	V		
Drain-Source On-Resistance	r _{DS(on)}	I _S = -10 mA, V _D = ±8.5 V V+ = 13.5 V, V- = -13.5 V	Room Full		50	85 100	Ω		
Switch Off Leakage Current	I _{S(off)}	V+ = 16.5 V, V- = -16.5 V V _D = ±15.5 V, V _S = ±15.5 V	Room Full	-0.5 -5	±0.01	0.5 5	nA		
	I _{D(off)}		Room Full	-0.5 -5	±0.01	0.5 5			
Channel On Leakage Current	I _{D(on)}	V+ = 16.5 V, V- = -16.5 V V _S = V _D = ±15.5 V	Room Full	-0.5 -10	±0.08	0.5 10			
Digital Control									
Input Current V _{IN} Low	I _{IL}	V _{IN} under test = 0.8 V All Other = 2.4 V	Full	-500	-0.01	500	nA		
Input Current V _{IN} High	I _{IH}	V _{IN} under test = 2.4 V All Other = 0.8 V	Full	-500	0.01	500			
Dynamic Characteristics									
Turn-On Time	t _{ON}	R _L = 1 kΩ, C _L = 35 pF V _S = ±10 V, See Figure 2	Room			120	250	ns	
Turn-Off Time	t _{OFF}		DG441	Room			110		140
			DG442	Room			160		210
Charge Injection ^e	Q	C _L = 1 nF, V _S = 0 V V _{gen} = 0 V, R _{gen} = 0 Ω	Room		-1		pC		
Off Isolation ^e	OIRR	R _L = 50 Ω, C _L = 5 pF, f = 1 MHz	Room			60		dB	
Crosstalk (Channel-to-Channel) ^d	X _{TALK}		Room			100			
Source Off Capacitance	C _{S(off)}	f = 1 MHz	Room			4		pF	
Drain Off Capacitance	C _{D(off)}		Room			4			
Channel On Capacitance ^e	C _{D(on)}		V _{ANALOG} = 0 V	Room			16		

Specifications for Dual Supplies (Cont'd)

Parameter	Symbol	Test Conditions Unless Otherwise Specified $V_+ = 15\text{ V}, V_- = -15\text{ V}$ $V_L = 5\text{ V}, V_{IN} = 2.4\text{ V}, 0.8\text{ V}^e$	Temp ^a	D Suffix -40 to 85°C			Unit
				Min ^c	Typ ^b	Max ^c	
Power Supplies							
Positive Supply Current	I+	$V_+ = 16.5\text{ V}, V_- = -16.5\text{ V}$ $V_{IN} = 0\text{ or }5\text{ V}$	Room Full		0.001	1 5	μA
Negative Supply Current	I-		Room Full	-1 -5	-0.000 1		
Logic Supply Current	I _L		Room Full		0.001	1 5	
Ground Current	I _{GND}		Room Full	-1 -5	-0.001		

Specifications for Unipolar Supplies

Parameter	Symbol	Test Conditions Unless Otherwise Specified $V_+ = 12\text{ V}, V_- = 0\text{ V}$ $V_L = 5\text{ V}, V_{IN} = 2.4\text{ V}, 0.8\text{ V}^e$	Temp ^a	D Suffix -40 to 85°C			Unit
				Min ^c	Typ ^b	Max ^c	
Analog Switch							
Analog Signal Range ^d	V _{ANALOG}		Full	0		12	V
Drain-Source On-Resistance ^d	r _{DS(on)}	$I_S = -10\text{ mA}, V_D = 3\text{ V}, 8\text{ V}$ $V_+ = 10.8\text{ V}, V_L = 5.25\text{ V}$	Room Full		100	160 200	Ω
Dynamic Characteristics							
Turn-On Time	t _{ON}	$R_L = 1\text{ k}\Omega, C_L = 35\text{ pF}, V_S = 8\text{ V}$ See Figure 2	Room		300	450	ns
Turn-Off Time	t _{OFF}		Room		60	200	
Charge Injection	Q	$C_L = 1\text{ nF}, V_{\text{gen}} = 6\text{ V}, R_{\text{gen}} = 0\text{ }\Omega$	Room		2		pC
Power Supplies							
Positive Supply Current	I+	$V_+ = 13.2\text{ V}, V_{IN} = 0\text{ or }5\text{ V}$	Room Full		0.001	1 5	μA
Negative Supply Current	I-	$V_{IN} = 0\text{ or }5\text{ V}$	Room Full	-1 -5	-0.000 1		
Logic Supply Current	I _L	$V_L = 5.25\text{ V}, V_{IN} = 0\text{ or }5\text{ V}$	Room Full		0.001	1 5	
Ground Current	I _{GND}	$V_{IN} = 0\text{ or }5\text{ V}$	Room Full	-1 -5	-0.001		

Notes:

- Room = 25°C, Full = as determined by the operating temperature suffix.
- Typical values are for DESIGN AID ONLY, not guaranteed nor subject to production testing.
- The algebraic convention whereby the most negative value is a minimum and the most positive a maximum, is used in this data sheet.
- Guaranteed by design, not subject to production test.
- V_{IN} = input voltage to perform proper function.

Typical Characteristics

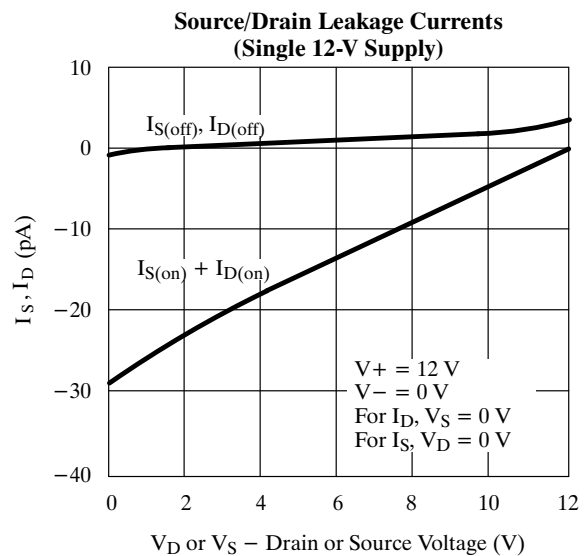
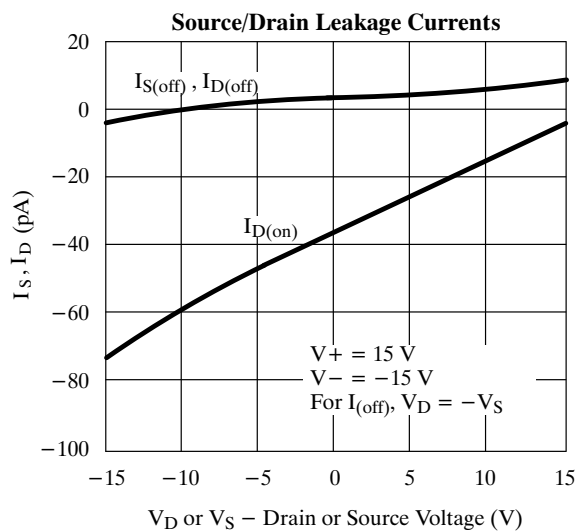
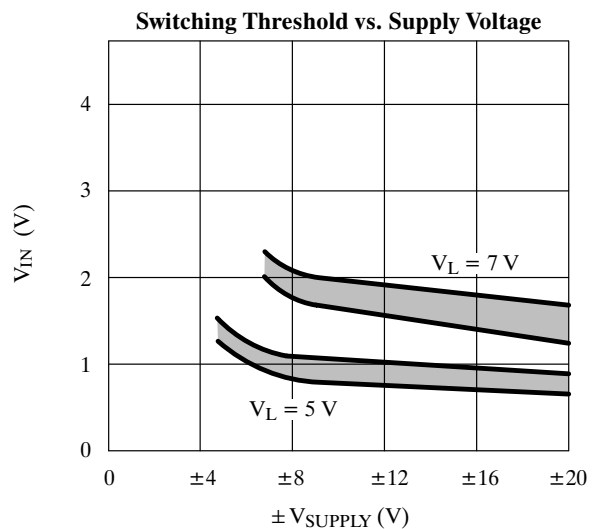
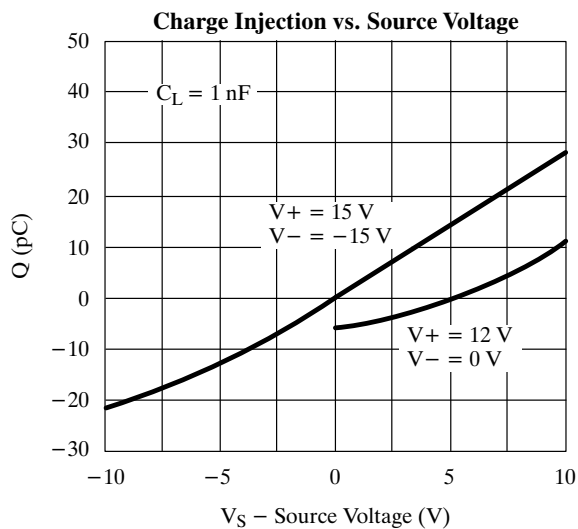
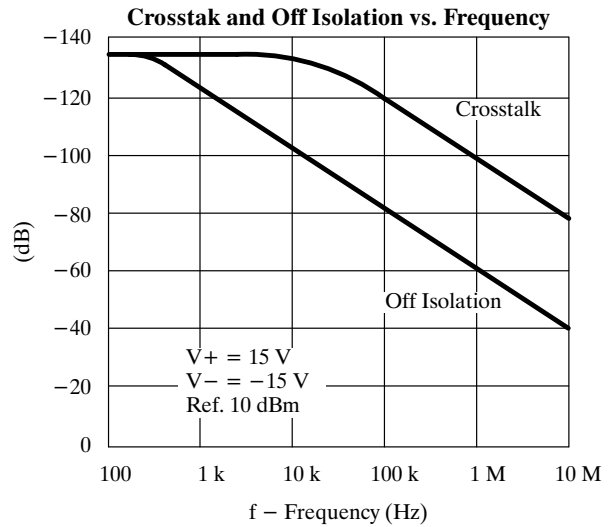
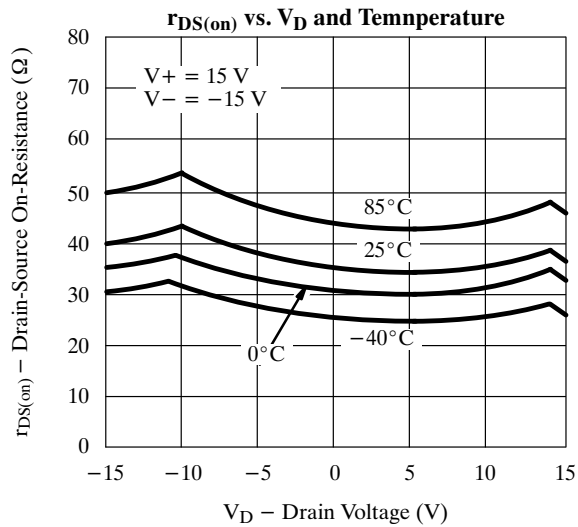

Typical Characteristics (Cont'd)

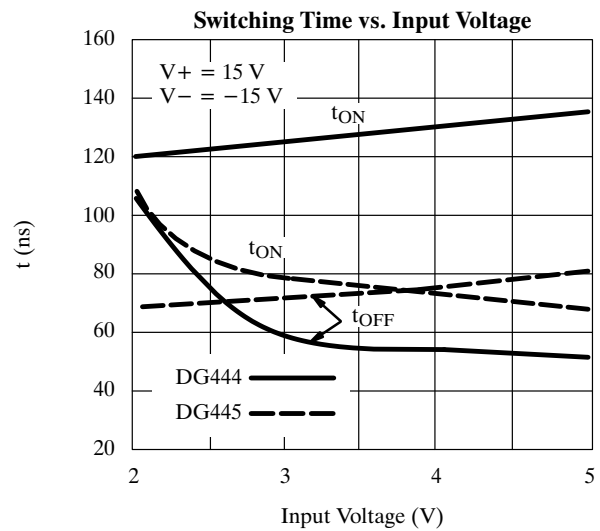
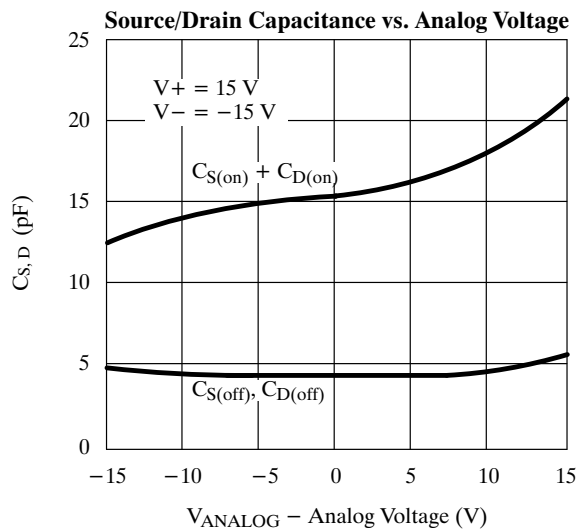
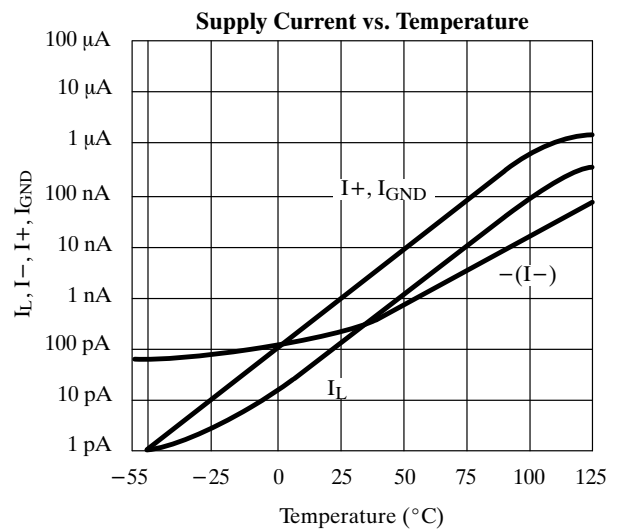
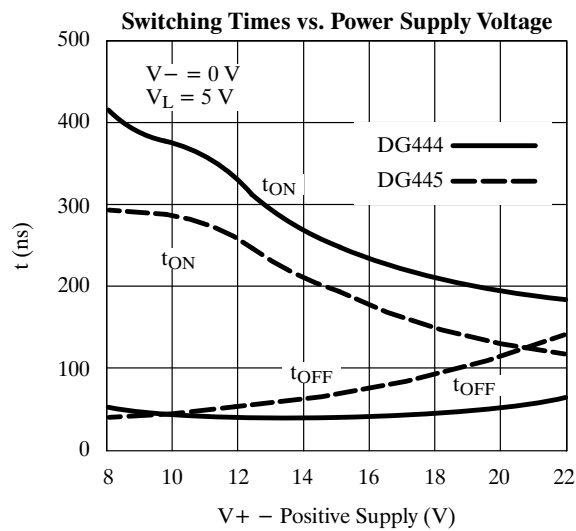
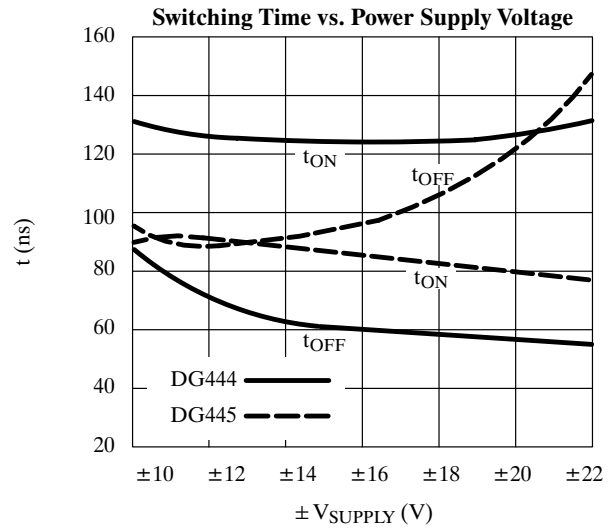
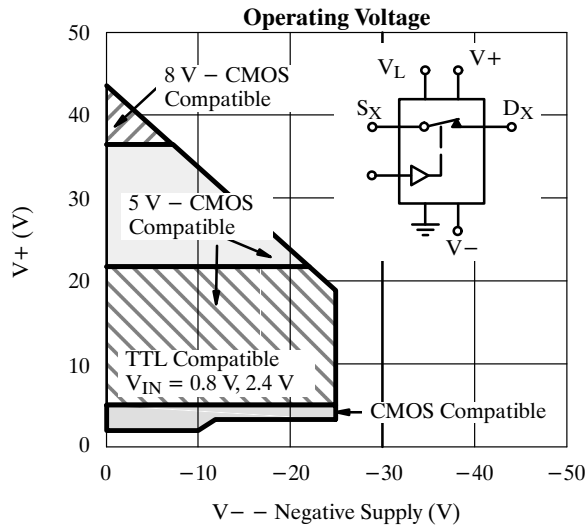

Schematic Diagram (Typical Channel)

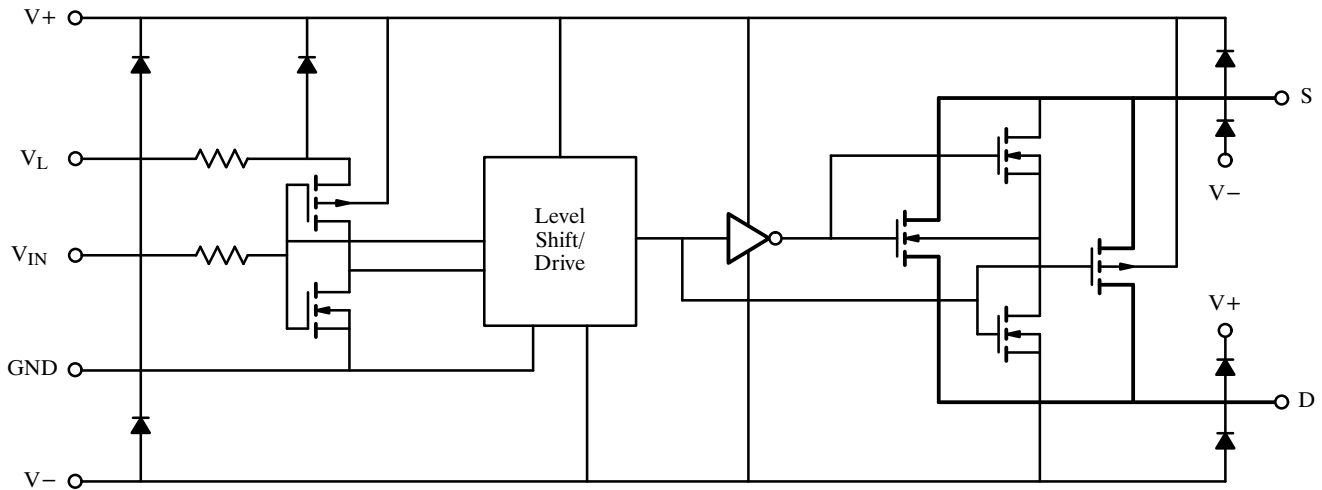
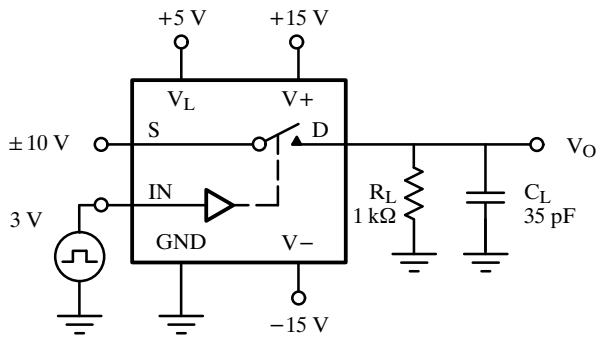
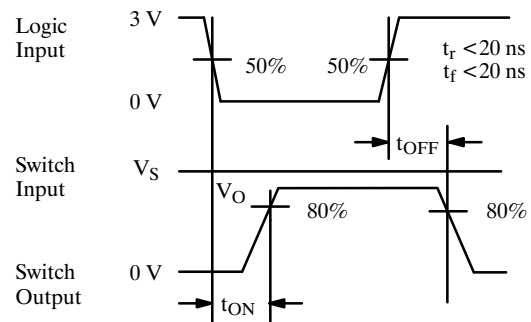

Figure 1.

Test Circuits



C_L (includes fixture and stray capacitance)



Note: Logic input waveform is inverted for DG445.

Figure 2. Switching Time

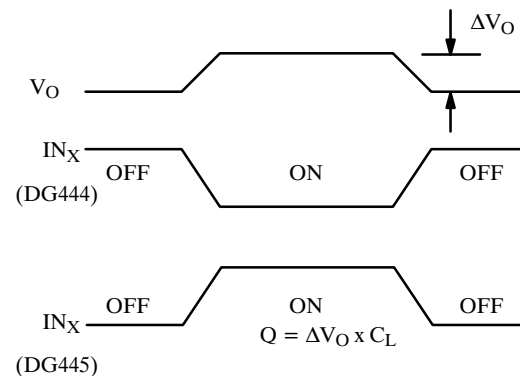
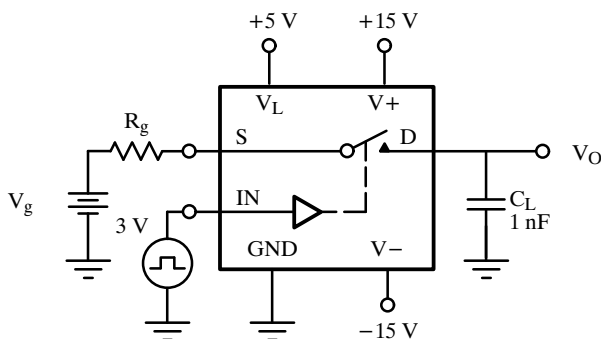

Figure 3. Charge Injection

Applications (Cont'd)

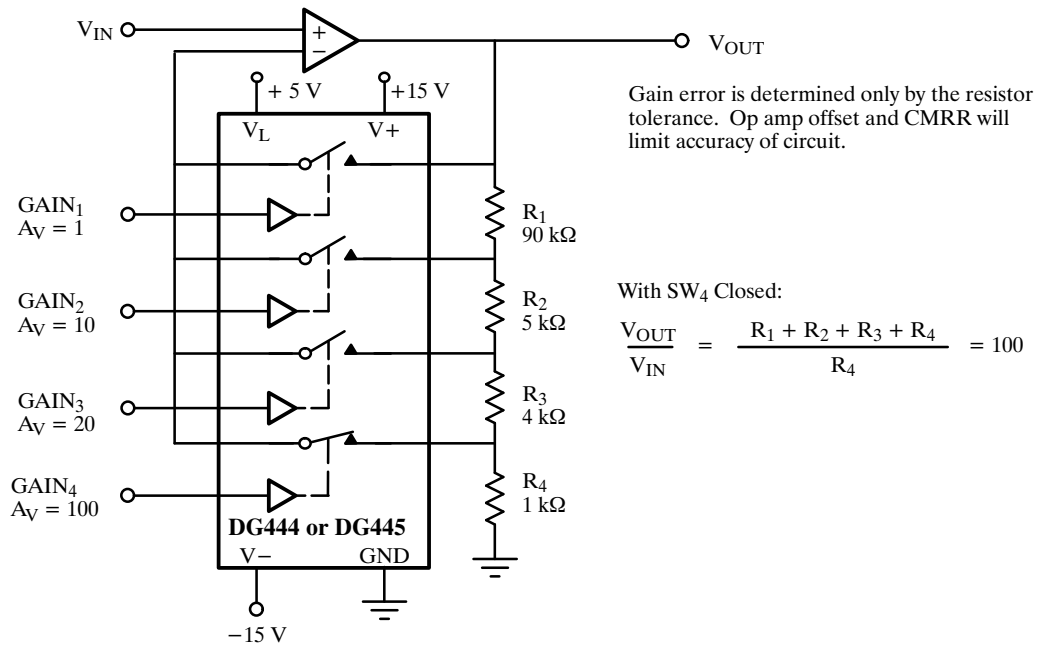

Figure 8. Precision-Weighted Resistor Programmable-Gain Amplifier

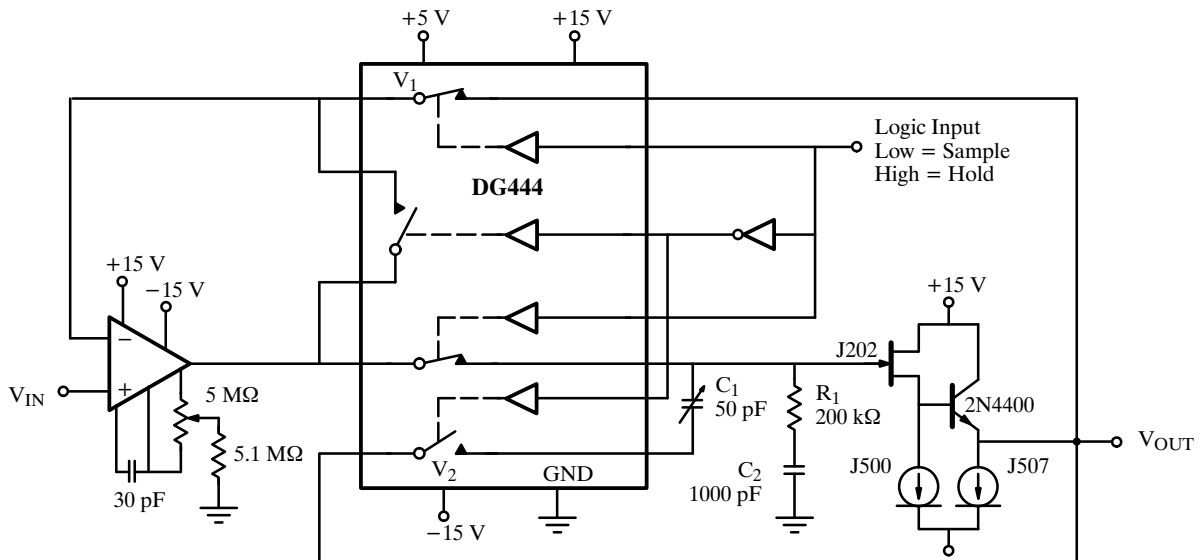

Figure 9. Precision Sample-and-Hold